

World Journal of *Hematology*

World J Hematol 2016 May 6; 5(2): 51-60



Editorial Board

2012-2016

The *World Journal of Hematology* Editorial Board consists of 123 members, representing a team of worldwide experts in hematology. They are from 29 countries, including Argentina (2), Austria (1), Belgium (1), Brazil (1), Canada (1), China (4), Croatian (1), Denmark (1), France (6), Germany (4), Greece (4), India (1), Iran (1), Ireland (1), Israel (2), Italy (11), Japan (9), Luxembourg (1), Mexico (1), Netherlands (7), Norway (2), Romania (1), Singapore (1), South Korea (2), Spain (6), Thailand (1), Turkey (5), United Kingdom (9), and United States (36).

EDITORS-IN-CHIEF

Xiaoyan Jiang, *Vancouver*
Thomas J Kipps, *San Diego*

GUEST EDITORIAL BOARD MEMBERS

Hwei-Fang Tien, *Taipei*

MEMBERS OF THE EDITORIAL BOARD



Argentina

Ricardo Forastiero, *Buenos Aires*
Mirta A Schattner, *Buenos Aires*



Austria

Richard H Moriggl, *Vienna*



Belgium

Xavier Sagaert, *Leuven*



Brazil

Constantino José Fernandes Jr, *São Paulo*



China

Anskar YH Leung, *Hong Kong*
Raymond HS Liang, *Hong Kong*
Xiao-Yu Tian, *Hong Kong*



Croatian

Mariastefania Antica, *Zagreb*



Denmark

Erik Lerkevang Grove, *Aarhus*



France

Emmanuel Andres, *Strasbourg*
Claude Bagnis, *Marseille*
Bernard Binetruy, *Marseille*
Cyril Fauriat, *Marseille*
Florence Nguyen Khac, *Paris*
Xavier Georges Thomas, *Pierre Benite*



Germany

Arnold Ganser, *Hannover*
Dirk Matthias Hermann, *Essen*
Rory R Koenen, *Munich*
Zhixiong Li, *Hannover*



Greece

Anastasios G Kriebardis, *Athens*
Marie-Christine Kyrtsolis, *Athens*
Gerassimos A Pangalis, *Athens*
Issidora S Papassideri, *Athens*



India

Gurudutta U Gangenahalli, *Delhi*



Iran

Shahram Teimourian, *Tehran*



Ireland

Eva Szegezdi, *Galway*



Israel

Jacob George, *Rehovot*
Avichai Shimoni, *Tel-Hashomer*



Italy

Luca Arcaini, *Pavia*
Vincenzo Casolaro, *Baronissi*
Alessia Colosimo, *Teramo*
Raimondo De Cristofaro, *Rome*
Claudio Fozza, *Sassari*
Edoardo G Giannini, *Genova*
Giampiero La Rocca, *Palermo*
Pier Paolo Piccaluga, *Bologna*
Alessandro Poggi, *Genoa*
Sergio M Siragusa, *Palermo*
Elena Zocchi, *Genova*



Japan

Xian Wu Cheng, *Nagoya*
Seiji Fukuda, *Izumo*
Satoshi Hagiwara, *Yufu*
Shinsaku Imashuku, *Takasago*
Masanobu Kitagawa, *Tokyo*
Tetsuya Nosaka, *Tsu*

Masao Seto, *Nagoya*
Toshiki Shimizu, *Moriguchi*
Masafumi Takahashi, *Shimotsuke*



Luxembourg

Jacques Zimmer, *Luxembourg*



Mexico

Agustin Avilés, *Mexico City*



Netherlands

Miranda Buitenhuis, *Rotterdam*
Roland P Kuiper, *Nijmegen*
Jan Jacques Michiels, *Erasmus*
Gerry AF Nicolaes, *Maastricht*
Pieter Sonneveld, *Rotterdam*
Arnold Spek, *Amsterdam*
Ruurd Torensma, *Nijmegen*



Norway

Brynjar Foss, *Stavanger*
Mikhail Sovershaev, *Tromsø*



Romania

Adriana Georgescu, *Bucharest*



Singapore

Jerry Chan, *Singapore*



South Korea

Jung Weon Lee, *Seoul*
Myung-Geun Shin, *Gwangju*



Spain

Matilde Canelles, *Granada*
Slaven Erceg, *Seville*
Pedro Cosme Redondo Liberal, *Cáceres*
Julian Pardo, *Zaragoza*
Josep-Maria Ribera, *Badalona*
Juan M Zapata, *Madrid*



Thailand

Chirayu Udomsakdi Auewarakul, *Bangkok*



Turkey

Mutay Aslan, *Antalya*
Murat Biteker, *Istanbul*
Taner Demirer, *Ankara*
Selami Kocak Toprak, *Ankara*
Ertan Yetkin, *Mersin*



United Kingdom

Dominique Bonnet, *London*
Olga Tura Ceide, *Edinburgh*
Helen A Ireland, *London*
Charles Henderson Lawrie, *Oxford*
Drew Provan, *London*
Dipak Purshottam Ramji, *Cardiff*
Sabrina Tosi, *Uxbridge*

Shao-An Xue, *London*
Jian guo Zhuang, *Liverpool*



United States

Ivo Abraham, *Tucson*
Julia E Brittain, *Chapel Hill*
Chung-Che Chang, *Houston*
Edward Alan Copelan, *Cleveland*
Zeev Estrov, *Houston*
Steve Fiering, *Lebanon*
Suzanne T Ildstad, *Louisville*
Elias Jabbour, *Houston*
Ming Jiang, *Nashville*
Katsuhiko Kita, *Galveston*
Robert G Lerner, *Valhalla*
Shaoguang Li, *Worcester*
Dazhi Liu, *Sacramento*
Ming-Lin Liu, *Philadelphia*
Surya Nauli, *Toledo*
Steffan Nawrocki, *San Antonio*
Xuyang Peng, *Nashville*
Manuel L Penichet, *Los Angeles*
Luis Francisco Porrata, *Rochester*
Rehan Qayyum, *Baltimore*
L Vijaya Mohan Rao, *San Diego*
Guangwen Ren, *New Brunswick*
Xiaoping Ren, *Cincinnati*
Jatin J Shah, *Houston*
Angus M Sinclair, *Thousand Oaks*
Ali A Sovari, *Chicago*
Christopher A Tormey, *New Haven*
Olga Volpert, *Chicago*
Zack Zhengyu Wang, *Scarborough*
EllenLori Weisberg, *Boston*
Wen-Shu Wu, *Scarborough*
Yi Wu, *Newark*
Feng-Chun Yang, *Indiana*
Karina Yazdanbakhsh, *New York*
Xin-Fu Zhou, *Adelaide*

W

J

H

World Journal of Hematology

Contents

Quarterly Volume 5 Number 2 May 6, 2016

MINIREVIEWS

- 51 Role of microRNA in regulation of myeloma-related angiogenesis and survival
Rahat MA, Preis M

ABOUT COVER

Editorial Board Member of *World Journal of Hematology*, Josep-Maria Ribera, MD, PhD, Doctor, Department of Clinical Hematology, ICO-Hospital Germans Trias I Pujol, 08916 Badalona, Spain

AIM AND SCOPE

World Journal of Hematology (*World J Hematol*, *WJH*, online ISSN 2218-6204, DOI: 10.5315) is a peer-reviewed open access academic journal that aims to guide clinical practice and improve diagnostic and therapeutic skills of clinicians.

WJH covers topics concerning experimental, clinical, oncological and transplant hematology, transfusion science, hemostasis and thrombosis, evidence-based medicine, epidemiology and nursing. Priority publication will be given to articles concerning diagnosis and treatment of hematological diseases. The following aspects are covered: Clinical diagnosis, laboratory diagnosis, differential diagnosis, imaging tests, pathological diagnosis, molecular biological diagnosis, immunological diagnosis, genetic diagnosis, functional diagnostics, and physical diagnosis; and comprehensive therapy, drug therapy, surgical therapy, interventional treatment, minimally invasive therapy, and robot-assisted therapy.

We encourage authors to submit their manuscripts to *WJH*. We will give priority to manuscripts that are supported by major national and international foundations and those that are of great basic and clinical significance.

INDEXING/ABSTRACTING

World Journal of Hematology is currently no indexing/abstracting.

FLYLEAF

I-II Editorial Board

EDITORS FOR THIS ISSUE

Responsible Assistant Editor: *Xiang Li*
Responsible Electronic Editor: *Huan-Liang Wu*
Proofing Editor-in-Chief: *Lian-Sheng Ma*

Responsible Science Editor: *Xue-Mei Gong*
Proofing Editorial Office Director: *Xiu-Xia Song*

NAME OF JOURNAL
World Journal of Hematology

ISSN
 ISSN 2218-6204 (online)

LAUNCH DATE
 June 6, 2012

FREQUENCY
 Quarterly

EDITORS-IN-CHIEF
Xiaoyan Jiang, MD, PhD, Associate Professor, Medical Genetics, University of British Columbia, Terry Fox Laboratory, British Columbia Cancer Agency, 675 West 10th Ave, Vancouver, BC, V5Z 1L3, Canada

Thomas J Kipps, MD, PhD, Professor of Medicine, University of California, San Diego, Moores Cancer Center, 3855 Health Sciences Drive, MC 0820, La Jolla,

CA 92093-0820, United States

EDITORIAL OFFICE
 Jin-Lei Wang, Director
 Xiu-Xia Song, Vice Director
World Journal of Hematology
 Beijing 100025, China
 Telephone: +86-10-59080039
 Fax: +86-10-85381893
 E-mail: editorialoffice@wjnet.com
 Help Desk: <http://www.wjnet.com/esps/helpdesk.aspx>
<http://www.wjnet.com>

PUBLISHER
 Baishideng Publishing Group Inc
 8226 Regency Drive,
 Pleasanton, CA 94588, USA
 Telephone: +1-925-223-8242
 Fax: +1-925-223-8243
 E-mail: bpgoffice@wjnet.com
 Help Desk: <http://www.wjnet.com/esps/helpdesk.aspx>
<http://www.wjnet.com>

PUBLICATION DATE
 May 6, 2016

COPYRIGHT
 © 2016 Baishideng Publishing Group Inc. Articles published by this Open Access journal are distributed under the terms of the Creative Commons Attribution Non-commercial License, which permits use, distribution, and reproduction in any medium, provided the original work is properly cited, the use is non commercial and is otherwise in compliance with the license.

SPECIAL STATEMENT
 All articles published in journals owned by the Baishideng Publishing Group (BPG) represent the views and opinions of their authors, and not the views, opinions or policies of the BPG, except where otherwise explicitly indicated.

INSTRUCTIONS TO AUTHORS
 Full instructions are available online at http://www.wjnet.com/2218-6204/g_info_20100722173604.htm.

ONLINE SUBMISSION
<http://www.wjnet.com/esps/>

Role of microRNA in regulation of myeloma-related angiogenesis and survival

Michal A Rahat, Meir Preis

Michal A Rahat, Immunology Research Unit, Carmel Medical Center, Haifa 3436212, Israel

Michal A Rahat, Ruth and Bruce Rappaport Faculty of Medicine, Technion, Haifa 3109601, Israel

Meir Preis, Institute of Hematology, Carmel Medical Center, Haifa 3436212, Israel

Author contributions: Both authors contributed equally to the concept of the paper, the writing of the manuscript and its critical revisions, and for its final approval.

Supported by The Israel Cancer Association, No. 20150048.

Conflict-of-interest statement: The authors have no conflict of interest.

Open-Access: This article is an open-access article which was selected by an in-house editor and fully peer-reviewed by external reviewers. It is distributed in accordance with the Creative Commons Attribution Non Commercial (CC BY-NC 4.0) license, which permits others to distribute, remix, adapt, build upon this work non-commercially, and license their derivative works on different terms, provided the original work is properly cited and the use is non-commercial. See: <http://creativecommons.org/licenses/by-nc/4.0/>

Correspondence to: Michal A Rahat, DSc, Assistant Professor, Immunology Research Unit, Carmel Medical Center, 7 Michal St., Haifa 3436212, Israel. rahat_miki@clalit.org.il
Telephone: +972-4-8250404
Fax: +972-4-8250408

Received: August 13, 2015
Peer-review started: August 13, 2015
First decision: November 6, 2015
Revised: November 19, 2015
Accepted: January 21, 2016
Article in press: January 22, 2016
Published online: May 6, 2016

Abstract

Multiple myeloma (MM) is a malignant disease caused

by clonal proliferation of plasma cells that result in monoclonal gammopathy and severe end organ damage. Despite the uniform clinical signs, the disease is very diverse in terms of the nature and sequence of the underlying molecular events. Multiple cellular processes are involved in helping the malignant cells to remain viable and maintain proliferative properties in the hypoxic microenvironment of the bone marrow. Specifically, the process of angiogenesis, triggered by the interactions between the malignant MM cells and the stroma cells around them, was found to be critical for MM progression. In this review we highlight the current understanding about the epigenetic regulation of the proliferation and apoptosis of MM cells and its dependency on angiogenesis in the bone marrow that is carried out by different microRNAs.

Key words: Multiple myeloma; MicroRNA; Angiogenesis; Proliferation; Apoptosis; Hypoxia; Vascular endothelial growth factor; Hypoxia-induce factor 1 α ; Macrophages; Endothelial cells

© The Author(s) 2016. Published by Baishideng Publishing Group Inc. All rights reserved.

Core tip: The pathogenesis of multiple myeloma (MM) requires that malignant cells remain viable and proliferate. Therefore, genes relating to the regulation of apoptosis, proliferation and angiogenesis are tightly regulated. Specifically, angiogenesis, which is driven by the interactions between the malignant cells and stroma cell surrounding them, is critical for MM progression. In this review we summarize the current knowledge about the regulation of the expression of genes related to apoptosis, proliferation and angiogenesis, through the activity of specific microRNAs.

Rahat MA, Preis M. Role of microRNA in regulation of myeloma-related angiogenesis and survival. *World J Hematol* 2016; 5(2): 51-60 Available from: URL: <http://www.wjgnet.com/2218-6204/full/v5/i2/51.htm> DOI: <http://dx.doi.org/10.5315/wjh.v5.i2.51>

INTRODUCTION

Multiple myeloma (MM) is an incurable B-cell neoplasm, where clonal plasma cells proliferate mostly within the bone marrow and produce high amounts of monoclonal paraprotein. Symptomatic myeloma is characterized by the presence of more than 10% clonal plasma cells on a bone marrow biopsy and the presence of end organ damage spanning hypercalcemia, renal insufficiency, anemia and bone lesions. Recently the International Myeloma Working Group added additional criteria to define the symptomatic disease^[1]. The disease itself always starts as a premalignant condition termed Monoclonal Gammopathy of Undetermined Significance (MGUS), characterized by a low number of bone marrow plasma cells, with low levels of monoclonal protein production. As the disease progresses the number of clonal plasma cells in the bone marrow increases. When the clonal plasma cells are more than 10% of the cells in the marrow with no evidence of the symptomatic disease it is termed "Smoldering Myeloma"^[2].

Despite the homogeneity in MM appearance, symptoms and disease progression, from a molecular standpoint, MM is a group of molecularly distinct diseases, with similar phenotypic characteristics. The events that generate the terminal state of MM are heterogeneous and diverse, and consist of hyperdiploidy, chromosomal aberrations such as translocations (especially those involving the immunoglobulin heavy chain locus at 14q32), chromosome deletions (such as in chromosome 13 or chromosome 17p), or combinations of translocation and dysregulation of at least one of the cyclin D genes. The latter is used to classify MM patients according to their translocation/cyclin (TC) status^[3]. These changes have significant prognostic implications, as patients with high risk disease changes such as translocation t4;14 and deletion of 17p have dismal prognosis^[4]. This diversity, of course, renders the study of the pathophysiology of the disease more difficult.

IMPORTANCE OF ANGIOGENESIS IN THE PATHOGENESIS OF MM

Angiogenesis, as a means of supplying oxygen and nutrients to the growing number of tumor cells, exists not only in solid tumors, but also in hematological malignancies, such as MM. Indeed, increased microvessel densities and elevated levels of pro-angiogenic factors such as vascular endothelial growth factor (VEGF), interleukin-6 (IL-6), insulin-like growth factors-1 (IGF-1), tumor necrosis factor alpha (TNF α), and granulocyte-macrophage colony stimulating factor in the bone marrow and serum of MM patients have been reported, and were associated with poor prognosis^[5-7]. Specifically, VEGF is overexpressed in malignant plasma

cells, and acts in a paracrine manner to enhance the proliferation and chemotaxis of endothelial cells, as well as other stroma cells^[5].

Existing therapies have anti-angiogenic properties

Existing therapeutic approaches to this disease include immunomodulatory drugs such as thalidomide, lenalidomide and pomalidomide, as well as proteasome inhibitors such as Bortezomib. These drugs target pro-angiogenic factors and have known anti-angiogenic properties, suggesting that their efficacy is at least partly due to their ability to block angiogenesis in MM development. Early experiments demonstrated the anti-angiogenic potential of Thalidomide^[8]. Lenalidomide was also found to inhibit migration and invasion of endothelial cells in a dose-dependent manner, as well as inhibiting VEGF-induced PI3K-Akt pathway signaling^[9]. Pomalidomide inhibits stromal cell adhesion and has been shown to markedly inhibit angiogenesis by decreasing concentration of VEGF and hypoxia-induce factor 1 α (HIF-1 α)^[10]. At pharmacological doses, bortezomib was found to inhibit endothelial cells proliferation, migration, and capillary formation. Bortezomib was also shown to decrease secretion of VEGF and IL-6 from myeloma cells^[11].

Angiogenesis is driven by interactions between tumor and stroma cells

The bone marrow microenvironment is heterogeneous, and consists of different immune cells (NK cells, B and T lymphocytes, monocytes, and dendritic cells), erythrocytes, hematopoietic stem cells, bone marrow mesenchymal stem cells, endothelial cells (ECs) and their precursors, fibroblasts, osteoblasts and osteoclasts - all closely associated with the extracellular matrix (ECM) that is primarily made of fibronectin, laminin, and collagen^[7], and organized in a special three-dimensional architecture with specialized niches^[12]. In MM this microenvironment also includes clonal plasma cells that depend for their survival and progression on the signals they receive from this microenvironment. MM cells that express the CXCR4 chemokine receptor, home into the bone marrow by moving along a gradient of the chemokine ligand SDF-1/CXCL12, which is secreted by the bone marrow stroma cells. Upon cell-cell interactions between the MM cells and the bone marrow stroma cells, additional cytokines are induced that promote MM cell proliferation and survival [Figure 1, *e.g.*, IL-6, IGF, TNF α , VEGF, basic fibroblast growth factor (bFGF)]^[13].

ECs also secrete matrix metalloproteinase-2 (MMP-2) and MMP-9 to help promote their migration, further assisting angiogenesis. Thus, ECs support MM tumor cell survival not only through angiogenesis, but also by promoting cells' invasiveness and dissemination^[7].

Thus, MM progression depends greatly on the tumor microenvironment and on the interaction of the tumor cells with the bone marrow stroma cells. However, the exact nature of those interactions, and the identity of all

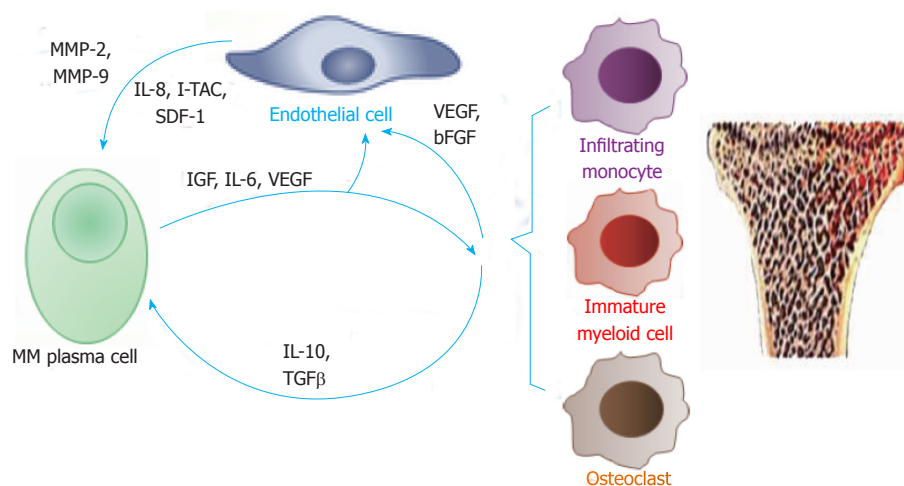

Figure 1 Cell-cell interactions that mediate angiogenesis (in a hypoxic microenvironment). Interactions between multiple myeloma plasma cells, endothelial cells and different myeloid cells (including infiltrating monocytes, immature myeloid cells such as myeloid-derived suppressor cells, and osteoclasts) stimulate secretion of pro-angiogenic factors. MMP: Matrix metalloproteinase; MM: Multiple myeloma; IL: Interleukin; I-TAC: Interferon-inducible T-cell alpha chemoattractant; SDF-1: Stromal cell-derived factor 1; IGF: Insulin-like growth factor; TGF β : Transforming growth factor beta; VEGF: Vascular endothelial growth factor; bFGF: Basic fibroblast growth factor.

the proteins mediating them is not yet fully elucidated.

VEGF expression and secretion depend on the local microenvironment

VEGF is highly important to MM progression and viability, due to its critical role in angiogenesis. Many factors collaborate to induce VEGF expression and secretion from MM tumor cells: Both stroma cells and tumor cells secrete IL-6 and IGF-1 that induce VEGF expression, as well as support MM cell growth; local hypoxia contributes to the induction of VEGF *via* the binding of HIF-1 α to its hypoxia response elements (HRE) site in the VEGF promoter; adhesion of the tumor cells to the ECM *via* β -integrins also contributes to VEGF induction^[7]. Secreted VEGF binds to VEGFR1 on tumor cells and stroma cells to act in both autocrine and paracrine manners. It enhances angiogenesis by promoting EC proliferation and migration, and recruits monocytes and circulatory endothelial precursors to the vasculature, where they may be incorporated into the blood vessels as pericytes or alternatively-activated macrophages. VEGF also enhances the expression of MMP-9^[7], that in turn may release VEGF from the ECM, resulting in a positive regulatory loop^[14].

The binding of the MM tumor cells to ECs and the binding of VEGF and bFGF to their receptors on ECs activate signaling events that lead to enhanced secretion of chemokines such as CXCL8/IL-8, CXCL11/I-TAC, CXCL12/SDF-1 and CCL-2/MCP-1. These chemokine ligands bind to their receptors on the MM tumor cells, thereby activating and maintaining the paracrine loop between these two cell types, and sustain proliferation and growth of the tumor cells^[12]. Additionally, these chemokines, as well as VEGF, are strong chemoattractants of monocytes and macrophages.

The number of bone marrow macrophages incre-

ases during active MM, and they can acquire EC-like properties, express EC proteins, and become incorporated into the tumor blood vessels^[12]. Moreover, they are an important source of VEGF production by themselves. Involvement of specific macrophage subsets in MM progression and MM-related angiogenesis has been identified within the bone marrow microenvironment. For example, osteoclasts can secrete osteopontin (OPN) and MMP-9, which together with VEGF promote angiogenesis. Myeloid-derived suppressor cells (MDSCs) which are heterologous immature myeloid cells, expand during MM, and exert immunosuppressive effects on the microenvironment, by recruiting regulatory cells (Tregs, more MDSCs and tumor-associated macrophages - TAMs), and by secreting low levels of nitric oxide and immunosuppressive cytokines, such as IL-10 and TGF β ^[15,16].

In both mice MM models and human patients, MDSCs expand in the bone marrow, as well as in the spleen and circulation, especially towards the end-stage of the disease, and these bone marrow-derived MDSCs were shown to suppress T cell activity *in vitro*^[15]. Additionally, these immature cells can differentiate into macrophages and further into osteoclasts, and MDSCs from MM mice models can differentiate into fully functional osteoclasts *in vitro* and *in vivo*, in higher numbers than MDSCs obtained from naïve mice^[15]. Since only MDSCs derived from the bone marrow, but not from the spleen or blood, can undergo this specific differentiation, it is assumed that some specific factor in the bone marrow microenvironment promotes this effect and leads to the generation of bone lesions generated by these osteoclasts. Furthermore, levels of EMMPRIN/CD147, a protein that has been shown to mediate interactions between tumor cells and macrophages, have recently been found to be elevated in plasma

cells (PCs) from MM patients relative to normal PCs. Higher expression levels of EMMPRIN were correlated to increased proliferation of these cells, whereas silencing of the protein reduced their proliferation^[17].

Collectively, all the above findings illustrate the importance of the interactions within the bone marrow microenvironment between the different cell types to the regulation of MM pathogenesis in general and MM-related angiogenesis in particular. MM tumor cells elicit stroma cells to produce pro-angiogenic and growth factors that they need for their survival and expansion, while reverse signaling that stroma cells initiate within the tumor cells help sustain these intricate interactions. However, the mechanisms that regulate such interactions require more investigation.

EPIGENETIC REGULATION BY MICRORNA

MicroRNA (miRNAs) are part of a family of non-coding, small (20-25 nucleotides) single-stranded RNA molecules that regulate mRNA translational, stability and degradation. These miRNAs recognize sequences of imperfect complementarity mostly in the 3' untranslated regions (UTRs) of target mRNAs (but also in the 5'-UTR or coding sequences), recruit the RNA-induced silencing complex (RISC) and mediate their translational inhibition. Sometimes miRNAs recognize sequences with perfect complementarity and cause these mRNAs to be degraded^[18,19]. More than one miRNA can bind to one transcript at a time, and each miRNA can target hundreds of transcripts, either by binding of their seed sequence (*i.e.*, the 2nd to 7th nucleotides from the 5' side of the mature miRNA) to the 3'-UTR of their target mRNA directly, or by indirectly targeting another transcript that codes for a regulator protein. The details of miRNA biosynthesis are excellently reviewed elsewhere^[20-22]. More than 700 human miRNAs have been identified so far, and their role in tumorigenesis and tumor promotion is a subject of intense research. Abnormal changes in the expression of miRNA have been associated with widespread dysregulation of gene expression, inflammation and diverse cancer diseases^[23]. Dysregulated expression of miRNA can contribute to tumorigenesis by modulating tumor suppressor genes and oncogene signaling pathways^[24]. For example, critical components of key signaling pathways, such as Myc, p53, phosphatase and tensin homolog (PTEN) and NF- κ B, are inhibited by miRNAs, leading to the description of miRNAs function as either oncogenes or tumor suppressor genes^[24,25].

MM represents a group of diseases that are molecularly distinct. Expression of miRNAs can be dysregulated due to different chromosomal aberrations and genetic mechanisms, or could be regulated directly by proteins involved in the biosynthesis of miRNAs. These miRNAs in turn, regulate the expression of other genes that contribute to the progression and invasiveness of the disease.

METHODOLOGIES USED IN THE STUDY OF MIRNA

In order to associate between a specific miRNA and its target gene, several approaches may be taken. The known sequence of the suspected target gene, and its 3'-UTR in particular, can be searched using different algorithms, which predict the binding of the seed sequence of the miRNA to the target gene^[26]. Algorithms, such as those supported by miRNA.org (<http://www.microrna.org/microrna/home.do>), TargetScan (<http://www.targetscan.org>), and PicTar (<http://pictar.mdc-berlin.de/>) are commonly used, but being only predictive tools, they do not necessarily identify real biological sites. Furthermore, these algorithms predict direct binding, but do not address the indirect effects of miRNA, which may affect protein translation through the inhibition of another protein. Therefore, direct binding of the miRNA to the target mRNA must be demonstrated, usually by transfecting tumor cell lines with a reporter construct that contains the 3'-UTR under a luciferase reporter and by measuring the chemiluminescence generated in different conditions.

In order to demonstrate the involvement of a specific miRNA in a biological function, several additional steps are required. First, changes in the expression levels of the specific miRNA could indicate potential regulation, as inhibition of target genes is likely to be affected accordingly. These expression levels are determined by quantitative reverse transcription polymerase chain reaction, and are most commonly normalized to the expression levels of the small nuclear RNAU6 or another stable miRNA that does not change under the experimental conditions. Then the expression levels of the target protein are correlated with the expression levels of the miRNA. Finally, overexpression of the miRNA or its neutralization must be shown to result in a change in the expression of the target protein. These gain or loss of function assays can be performed by transfecting the cells *in vitro* with miRNA mimics or pre-miRNA, or with anti-miRNA (antagomir), respectively. Alternatively, miRNA can be depleted by transfecting the cells with "miRNA sponges", which are plasmid constructs that contain multiple miRNA-binding sites for specific miRNAs under the regulation of a strong promoter, to ensure their high expression^[27,28].

INVOLVEMENT OF SPECIFIC MIRNAS IN MM CELL PROLIFERATION AND APOPTOSIS

Dysregulation of miRNA expression, due to chromosomal aberrations and other genetic alterations, may contribute to the dysregulated expression of target genes in MM. In fact, specific miRNA signatures were shown to be associated with specific cytogenetic subgroups in MM^[3]. In the remaining parts of this review we will

Table 1 Involvement of microRNAs in multiple myeloma cell proliferation and apoptosis

Activator	miRNA reduced	miRNA overexpressed	Target increased	Target decreased	Effect	Ref.
Deletion, other	miR-15a, miR-16		AKT, S6, MAPK, MAP3KIP3 (TAB3)		Increased proliferation and survival	[30]
	miR-30-5p family		BCL9		Increased Wnt/ β -catenin activation	[32]
c-Myc (reduced)	miR-17/92 cluster		Bim		Increased apoptosis	[36,40]
Sp-1 (increased)	miR-29b		Sp-1, CDK6, Mcl-1, caspase-3, Rb phosphorylation			[41,42]
	miR-34a, miR-192, miR-194, miR-215		MDM2, IGF-1		Cell proliferation	[34]
		miR-19a/b		SOCS1, Bim	Reduced apoptosis	[36]
		miR-181a/b, miR-32		PCAF	Reduced p53 acetylation	[36]
		miR-221, miR-222		P27Kip1, p57Kip2, PUMA, PTEN	Increased proliferation	[35]
IL-6		miR-21		STAT-3		[37,38]

AKT: Protein kinase B; MAPK: Mitogen-activated protein kinases; MAP3KIP3: Mitogen-activated protein 3 kinase interacting protein 3; BCL9: B-cell lymphoma 9 protein; MDM2: Mouse double minute 2; IGF-1: Insulin-like growth factor 1; SOCS1: Suppressor of cytokine signaling 1; PCAF: P300/CBP-associated factor; PTEN: Phosphatase and tensin homolog; STAT-3: Signal transducer and activator of transcription 3; PUMA: p53 upregulated modulator of apoptosis; IL-6: Interleukin 6.

describe what is known so far about the involvement of miRNAs in the pathogenesis of MM, focusing specifically on those miRNA that regulate MM-related angiogenesis.

The mechanisms that lead to the dysregulated expression of miRNAs in MM cells are not always fully elucidated. In some cases, the malignant transformation itself, *i.e.*, translocation of chromosomal fragments or deleted chromosome segments, could lead to either reduction or complete loss of some miRNA's expression, or to enhanced expression of other miRNAs that could down-regulate the expression of a protein needed for the transcription of another miRNA. Indeed, a correlation between deregulated miRNA expression and cytogenetic abnormalities in MM cells was recently found^[29]. In other cases, DNA methylation of promoters that encode for miRNAs was found, resulting in their silenced expression^[13]. Thus, different mechanisms could lead to aberrant expression of miRNAs and their involvement in MM pathogenesis.

Many of the miRNAs that were shown to contribute to MM pathogenesis actually regulate MM cell proliferation and/or apoptosis (summarized in Table 1). Central to these regulatory loops are miR-15a and miR-16 that are located as a cluster on chromosome 13q14, an area commonly deleted in MM. Thus, patients with deletion in chromosome 13, which make up about 50% of MM patients, also exhibited total lack of miR-15a and miR-16^[30]. In patients whose chromosome 13

is not deleted, miR-15a and miR-16 expression is often reduced, and is inversely correlated with advanced stage of the disease^[31]. The reduced expression levels of miR-15a and miR-16 regulate proliferation and growth of MM cells both *in vitro* and *in vivo* in the bone marrow microenvironment, by inhibiting several target proteins, such as the AKT serine/threonine protein kinase (AKT3), ribosomal-protein-S6, MAP kinases, and the NF- κ B activator MAP3KIP3 (TAB3)^[30]. Specifically, NF- κ B activation plays a pivotal role in promoting growth and survival of MM cells, and is regulated by the interaction of MAP3KIP3 with TAK1. When MM cells were transfected with pre-miR-15a and pre-miR-16-1, MAP3KIP3 protein expression levels were reduced, and consequently, TNF α -activation of the NF- κ B family of proteins p65, p50 and p52, that normally results in their recruitment into the nucleus, was inhibited, whereas phosphorylated I κ B was increased in the cytoplasm. Thus, MAP3KIP3 is a validated target gene of miR-15a and miR-16^[30].

The family of miR-30-5p (including miR-30a-5p, miR-30b-5p, miR-30c-5p, miR-30d-5p, and miR-30e-5p) is down-regulated in plasma cells derived from MM patients, compared to normal cells. Since this family targets BCL9, a critical transcriptional coactivator of β -catenin, its absence causes the Wnt/ β -catenin pathway to be over-active, and promotes MM cell proliferation, survival, migration, drug resistance,

and formation of MM cancer stem cells^[32]. In fact, the Wnt/ β -catenin pathway is constitutively active in MM, promoting tumor cell proliferation, and resistance to chemotherapy^[33].

Involvement of wild type p53 in MM pathogenesis is also regulated by the down-regulation of miR-34a, miR-192, miR-194 and miR-215 in some MM patients and cell lines, which is caused by the hyper-methylation of their respective promoters. Reduced levels of these miRNAs that directly target MDM2, the negative regulator of the p53, disrupt the balance between MDM2 and p53, and favors MDM2 stability. In contrast, overexpressing these miRNAs in MM cells carrying the wild type TP53 results in growth arrest^[34].

Overexpression of other miRNAs creates similar effects, and several examples illustrate the complementary role they play in the regulation of cell proliferation and apoptosis. Proliferation of MM cells is partly regulated by miR-221/222, and some MM cells, such as the TC2 and TC4 subtypes that share the t(4:14) translocation, highly express miR-221/222. The neutralization of miR-221/222 in these MM cells reduced proliferation and up-regulated the expression of their target genes p27Kip1, PUMA, PTEN, and p57Kip2^[35]. In another study, overexpression of miRNA-222, miR-221, miR-382, miR-181a and miR-181b was found in MM CD138⁺ cells in comparison to normal cells, without assigning to them specific functions. However, their targets were predicted to be tumor suppressors, cytokine signaling suppressors (SOCS1, SOCS6), pro-apoptotic factors, NF- κ B suppressors, and tyrosine phosphatases^[30]. In support of these results, another study found overexpression of miR-32, miR-181a, miR-181b and also miR-21 that were demonstrated to target the p300-CBP-associated factor, that positively regulates p53 by acetylation^[36].

IL-6 is essential as a growth factor for B cells and can also up-regulate miR-21 expression through activation of STAT-3, which has two binding sites in the miR-21 promoter. Thus, ectopic overexpression of miR-21 could sustain growth of MM cells, even in the absence of IL-6^[37]. Moreover, a positive feedback loop exists, as miR-21 inhibits the expression of the protein inhibitor of activated STAT3, leading to enhanced STAT3 signaling^[38]. In patients or human MM cell lines that are intrinsically resistant or develop resistance over time to treatment with bortezomib, elevated levels of miR-21 can be found, whereas in responding cells or patients, bortezomib reduces miR-21 levels^[39]. Thus, miR-21 may become an attractive target for enhancing treatment efficiency in MM patients. Additionally, miR-19a and miR-19b were also found to be overexpressed, and were shown to inhibit the expression of SOCS1 and of the pro-apoptotic protein BIM/BCL2L11^[36].

Expression of the c-Myc oncogene can be dysregulated in many MM patients, due to chromosomal translocations or other mechanisms. Silencing of c-Myc in MM cell lines leads to reduced cell proliferation and triggers apoptosis, as well as inhibited expression of the

miR-17-92 cluster, demonstrating that c-Myc positively regulates this cluster. Triggering of apoptosis in these cells was the result of strong activation of the pro-apoptotic Bim protein, whereas the anti-apoptotic Bcl2 or Bcl-xL proteins were unaffected. Overexpression of miR-17 and miR-18, that belong to this cluster, even in the absence of c-Myc, inhibited Bim expression. Thus, Bim is directly regulated by the miR-17-92 cluster, which is in turn, activated by c-Myc, and these results implicate the cluster in the process of apoptosis^[40].

In MM patients and MM cell lines the expression of miR-29b is down-regulated. Overexpression of miR-29b inhibits cell growth and induces apoptosis in MM cells, partly by directly targeting the anti-apoptotic protein Mcl-1 and by activating caspase-3^[41]. Additionally, the anti-proliferative and pro-apoptotic properties of miR-29b are partly exerted by its inhibitory effects on Sp1 expression. On the other hand, Sp1 regulates miR-29b transcription, generating a negative feedback loop between the two factors. The proteasome inhibitor bortezomib affects this miR-29b-Sp1 loop by decreasing Sp1 and elevating miR-29b expression. Likewise, PI3K/AKT is also involved in the regulation of this balance between the two factors, as it works as a negative regulator of miR-29b expression^[42].

SPECIFIC MIRNAS TARGETING

MEDIATORS OF ANGIOGENESIS IN MM

Angiogenesis plays a crucial role in the pathogenesis and progression of MM, and greatly depends on the interactions of MM cells with the stroma cells, particularly endothelial cells and macrophages. These interactions may lead to changes in the expression of different miRNAs and consequently to regulation of their target gene expression (Figure 2).

The key cells involved in angiogenesis are the endothelial cells, and to promote angiogenesis, MM tumor cells must support their proliferation and migration by releasing VEGF in a paracrine manner. VEGF mediates vascular permeability and induce endothelial cell growth and migration to allow angiogenesis, invasiveness and metastasis. It is also a chemoattractant to macrophages and a regulator of MMP-9, thus it can also indirectly enhance angiogenesis^[43]. Therefore, VEGF is perhaps the most potent pro-angiogenic factor known, and its enhanced expression, along with other pro-angiogenic factors, is regulated at several check points including by miRNAs.

First, hypoxia has been shown to induce VEGF expression by the binding of the HIF-1 α transcription factor to its binding site (HRE) on the VEGF promoter, as well as to other pro-angiogenic factors such as angiopoietin-2, MMPs, and semaphoring 4D. Local and chronic hypoxia is generated in the bone marrow due to the increasing metabolic needs of proliferating MM cells. Although the bone marrow is naturally hypoxic, studies show that the oxygen tension levels in MM

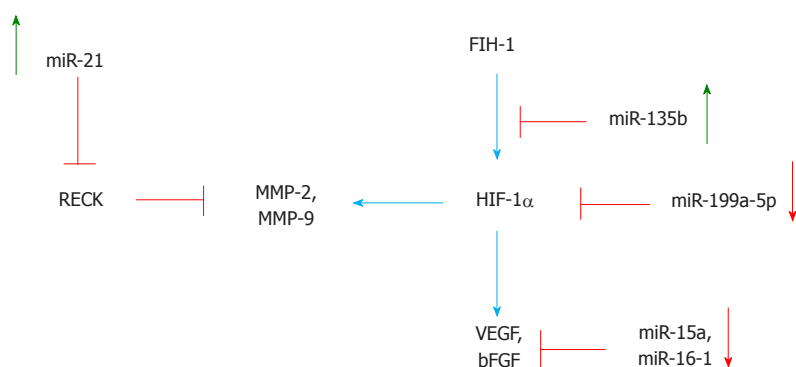

Figure 2 Key mediators of angiogenesis in multiple myeloma and their regulation by miRNAs. Pro-angiogenic factors are subject to regulation by hypoxia that triggers hypoxia-inducible factor 1α , and by other signals (e.g., TGF β , TNF α), and are fine-tuned by different microRNAs. Green arrows, increased expression levels; red arrows, decreased expression levels. RECK: Reversion-inducing-cysteine-rich protein with kazal motifs; MMP: Matrix metalloproteinase; FIH-1: Factor inhibiting HIF-1; HIF-1 α : Hypoxia-inducible factor 1-alpha; VEGF: Vascular endothelial growth factor; bFGF: Basic fibroblast growth factor.

bone marrow are even lower^[44]. This prolonged hypoxic microenvironment exerts pressure on the malignant cells, and those surviving MM cells, which become hypoxia-resistant, were shown to secrete twice the amount of miR-135b-containing exosomes. These exosomes were up-taken by endothelial cells, and their cargo of miR-135b directly targeted the factor inhibiting HIF-1, which inhibits HIF-1 α activity. Thus, prolonged, but not acute hypoxia, can mediate interactions between MM tumor cells and endothelial cells to elevate angiogenesis^[45]. However, it should be remembered that hypoxic exosomes may contain additional miRNAs, in addition to miR-135b, that might work cooperatively with miR-135b to regulate angiogenesis^[46]. Hypoxia also works through the down-regulation of miR-199a-5p expression, which directly targets HIF-1 α . Thus, hypoxic MM cells up-regulate HIF-1 α and through it induce the expression of several pro-angiogenic factors, such as VEGF, IL-8, bFGF, and CXCL-12/SDF-1, whereas MM cells transfected with synthetic miR-199a-5p showed reduced expression of these factors^[47]. Conditioned medium obtained from such cells and incubated with human umbilical vein endothelial cells (HUVEC) caused their reduced migration and inhibited production of VEGF, VCAM-1, ICAM-1 and IL-8^[47], again demonstrating the importance of tumor-stroma cells interactions for induction of angiogenesis.

Secondly, VEGF and bFGF are predicted target genes for miR-15a and miR16. Accordingly, MM cell lines that were transfected with pre-miR-15a and pre-miR-16-1 demonstrated reduced secretion of VEGF^[30,31], and conditioned medium from these cells reduced the activation of the ERK or AKT pathways in endothelial cells, resulting in their reduced ability to form tube-like formations *in vitro*^[30].

Enzymes that are involved in the biosynthesis of miRNAs also indirectly regulate angiogenesis, by affecting specific miRNAs expression. For example, argonaute 2 (Ago2) is a core component of the RISC. Supernatants from Ago2-overexpressing MM cell lines induced HUVEC migration and accelerated tube

formation, whereas supernatants from Ago2-knockdown MM cell lines suppressed HUVEC cell migration and tube formation^[48]. This effect was mediated through Ago2-driven up-regulation of 25 miRNAs (including members of the let 7 family and the miR-17/92 cluster) and down-regulation of 7 miRNAs (including miR-145 and miR-361). The 17/92 cluster includes miR-92-1, which was up-regulated by Ago2, targeted the angiopoietin-like protein 1 (ANGPTL1, an anti-angiogenic protein with tumor-inhibiting properties), and down-regulated its expression^[48]. Overexpression of Ago2 in MM cells also resulted in the down-regulation of miR-145, which directly targets VEGF, and therefore, increased VEGF expression^[48] (Table 2).

Lastly, in MM cells, miR-21 is upregulated, in reverse correlation to the down-regulated expression of reversion-inducing-cysteine rich protein with kazal motifs (RECK), a protein inhibitor of MMP-2 and MMP-9^[49]. Hypoxic MM cells show increased levels of MMP-2 expression, whereas enforced expression of miR-199a-5p in these cells reduced MMP-2 levels^[47].

USING MIRNAS AS BIOMARKERS OF MM AND AS POTENTIAL THERAPY FOR MM

Attempts have been made to use miRNA expression profiles as biomarkers for MM progression, or for classification of the MM cells into specific cytogenetic subtypes. Some miRNA arrays have been used to identify specific signatures or miRNA profiles that characterize different stages of MM progression and differentiate between MGUS and symptomatic MM^[3,36]. Since miRNAs are involved in MM pathogenesis and regulate many of the molecular processes that dictate the course of the disease, it is reasonable to assume that miRNA profiling or determination of expression of specific miRNA may have diagnostic and/or prognostic value. Given their reported stability in serum^[50], miRNA expression may represent novel non-invasive biomarkers of MM. This seems a promising direction for further study.

Table 2 Involvement of microRNAs in the regulation of multiple myeloma-related angiogenesis

	Target increased	Target reduced	Effect (anti-angiogenic)	Effect (pro-angiogenic)	Ref.
miRNA reduced					
miR-15a, miR-16, miR-145	VEGF, ERK pathway, AKT pathway		Reduced EC growth, reduced ability to form capillary structures		[30,31,48]
miR-199a-5p	HIF-1 α , SIRT-1		Increased expression of VEGF, IL-8, bFGF, CXCL12, MMP-2		[47]
miRNA increased					
Let 7 family		Thrombospondin-1, TIMP-1		Inhibiting anti-angiogenic factors	[48]
miR-92-1 miR-135b		Angiopoietin-like protein 1 FIH-1		Inhibit anti-angiogenic protein Alleviate HIF-1 α inhibition	[48] [45]

VEGF: Vascular endothelial growth factor; ERK: Extracellular signal-regulated kinase; HIF-1 α : Hypoxia inducible factor 1 alpha; SIRT-1: Sirtuin 1; FIH-1: Factor inhibiting HIF-1; IL-8: Interleukin-8; bFGF: Basic fibroblast growth factor; MMP: Matrix metalloproteinase.

Furthermore, the dysregulated expression of miRNAs places them as novel candidate therapeutic targets. Because miRNAs simultaneously target the expression of several genes and regulate key signaling pathways, targeting them is likely to be more beneficial than conventional approaches targeting a single protein with a single drug^[51]. The problem of delivering small RNA molecules to tumor cells within the bone marrow without using viral vectors, and then making sure that the miRNAs or antagomirs are taken up specifically by the tumor cells has been addressed by developing lipid-based or polymer-based delivery systems^[51]. Another possible advantage of using miRNA for therapy is the relative ease of detecting aberrant expression of specific miRNAs in the serum of MM patients or even in their bone marrow, and the ability to closely follow up on changes of miRNAs expression in response to treatment. Collectively, these advantages may promote, in the future, a personalized medicine approach, where patients will be specifically-tailored with antagomirs or miRNA mimics according to their personal miRNA expression profile, hopefully increasing the success of the treatment.

Currently, there are only a limited number of studies demonstrating the efficiency of targeting miRNAs as therapeutic means in MM, mostly carried out as pre-clinical trials using immunocompromised mice. One study introduced a mix of miRNAs from the miR-30 family, or just miR-30c, into MM cells, and observed reduction in tumor burden and in metastases in three human MM xenograft models, without adverse effects such as bone lesion. This effect was attributed to the ability of the miR-mimics to reduce and keep in check the expression of BCL9, the transcriptional coactivator of the Wnt signaling pathway^[32]. Overexpression of miR-199a-5p in human MM NCI-H929 xenograft in NOD/SCID mice was achieved by six intra-tumoral injections, every 3 d, of 20 μ g each encased in neutral lipid emulsion. This treatment reduced tumor growth and prolonged survival of the treated mice in comparison to the control mice^[47]. The only example so far, to

the best of our knowledge, which targets MM-related angiogenesis is the injection of miR-15a and miR-16 to the tail vein of mice bearing s.c. human MM xenografts, where reduced tumor size was observed due to reduced angiogenesis^[31].

CONCLUSION

MiRNA have a key role in MM, regulating cellular processes that are essential to disease initiation and progression. Most studies in the field focus on the involvement of miRNA in the regulation of tumor cell proliferation, survival, and apoptosis. Only a limited number of studies investigate the involvement of miRNAs in the regulation of angiogenesis, a process that is critical to disease progression and especially to the malignant transformation from MGUS to MM. Thus, manipulation of this process represents a promise to attenuate the progression of the tumor to the malignant stage. Furthermore, the novel drugs, such as thalidomide, lenalidomide and bortezomib have been shown to exert an anti-angiogenic effect in MM patients. Understanding how they regulate miRNAs may lead to better treatment approaches by fine-tuning the drugs' properties to manipulate specific miRNAs expression. We therefore anticipate and hope that the following years will lead to exciting new investigations into the involvement of miRNA in MM pathogenesis, and specifically in MM-related angiogenesis, studies that will hopefully be implemented in treatment of this still incurable disease.

REFERENCES

- 1 **Rajkumar SV**, Dimopoulos MA, Palumbo A, Blade J, Merlini G, Mateos MV, Kumar S, Hillengass J, Kastritis E, Richardson P, Landgren O, Paiva B, Dispenzieri A, Weiss B, LeLeu X, Zweegman S, Lonial S, Rosinol L, Zamagni E, Jagannath S, Sezer O, Kristinsson SY, Caers J, Usmani SZ, Lahuerta JJ, Johnsen HE, Beksac M, Cavo M, Goldschmidt H, Terpos E, Kyle RA, Anderson KC, Durie BG, Miguel JF. International Myeloma Working Group updated criteria for the diagnosis of multiple myeloma. *Lancet*

- Oncol* 2014; **15**: e538-e548 [PMID: 25439696 DOI: 10.1016/S1470-2045(14)70442-5]
- 2 **International Myeloma Working Group.** Criteria for the classification of monoclonal gammopathies, multiple myeloma and related disorders: a report of the International Myeloma Working Group. *Br J Haematol* 2003; **121**: 749-757 [PMID: 12780789]
 - 3 **Lionetti M,** Biasiolo M, Agnelli L, Todoerti K, Mosca L, Fabris S, Sales G, Deliliers GL, Biccato S, Lombardi L, Bortoluzzi S, Neri A. Identification of microRNA expression patterns and definition of a microRNA/mRNA regulatory network in distinct molecular groups of multiple myeloma. *Blood* 2009; **114**: e20-e26 [PMID: 19846888 DOI: 10.1182/blood-2009-08-237495]
 - 4 **Chng WJ,** Dispenziera A, Chim CS, Fonseca R, Goldschmidt H, Lentzsch S, Munshi N, Palumbo A, Miguel JS, Sonneveld P, Cavo M, Usmani S, Durie BG, Avet-Loiseau H. IMWG consensus on risk stratification in multiple myeloma. *Leukemia* 2014; **28**: 269-277 [PMID: 23974982 DOI: 10.1038/leu.2013.247]
 - 5 **Medinger M,** Passweg J. Role of tumour angiogenesis in haematological malignancies. *Swiss Med Wkly* 2014; **144**: w14050 [PMID: 25375891 DOI: 10.4414/SMW.2014.14050]
 - 6 **Munshi NC,** Wilson C. Increased bone marrow microvessel density in newly diagnosed multiple myeloma carries a poor prognosis. *Semin Oncol* 2001; **28**: 565-569 [PMID: 11740810]
 - 7 **Podar K,** Anderson KC. The pathophysiologic role of VEGF in hematologic malignancies: therapeutic implications. *Blood* 2005; **105**: 1383-1395 [PMID: 15471951 DOI: 10.1182/blood-2004-07-2909]
 - 8 **D'Amato RJ,** Loughnan MS, Flynn E, Folkman J. Thalidomide is an inhibitor of angiogenesis. *Proc Natl Acad Sci USA* 1994; **91**: 4082-4085 [PMID: 7513432]
 - 9 **Lu L,** Payvandi F, Wu L, Zhang LH, Hariri RJ, Man HW, Chen RS, Muller GW, Hughes CC, Stirling DI, Schafer PH, Bartlett JB. The anti-cancer drug lenalidomide inhibits angiogenesis and metastasis via multiple inhibitory effects on endothelial cell function in normoxic and hypoxic conditions. *Microvasc Res* 2009; **77**: 78-86 [PMID: 18805433 DOI: 10.1016/j.mvr.2008.08.003]
 - 10 **Chanan-Khan AA,** Swaika A, Paulus A, Kumar SK, Mikhael JR, Rajkumar SV, Dispenziera A, Lacy MQ. Pomalidomide: the new immunomodulatory agent for the treatment of multiple myeloma. *Blood Cancer J* 2013; **3**: e143 [PMID: 24013664 DOI: 10.1038/bcj.2013.38]
 - 11 **Roccaro AM,** Hideshima T, Raje N, Kumar S, Ishitsuka K, Yasui H, Shiraishi N, Ribatti D, Nico B, Vacca A, Dammacco F, Richardson PG, Anderson KC. Bortezomib mediates antiangiogenesis in multiple myeloma via direct and indirect effects on endothelial cells. *Cancer Res* 2006; **66**: 184-191 [PMID: 16397231 DOI: 10.1158/0008-5472.CAN-05-1195]
 - 12 **Ribatti D,** Moschetta M, Vacca A. Microenvironment and multiple myeloma spread. *Thromb Res* 2014; **133** Suppl 2: S102-S106 [PMID: 24862128 DOI: 10.1016/S0049-3848(14)50017-5]
 - 13 **Wong KY,** Huang X, Chim CS. DNA methylation of microRNA genes in multiple myeloma. *Carcinogenesis* 2012; **33**: 1629-1638 [PMID: 22715154 DOI: 10.1093/carcin/bgs212]
 - 14 **Hollborn M,** Stathopoulos C, Steffen A, Wiedemann P, Kohen L, Bringmann A. Positive feedback regulation between MMP-9 and VEGF in human RPE cells. *Invest Ophthalmol Vis Sci* 2007; **48**: 4360-4367 [PMID: 17724228 DOI: 10.1167/iovs.06-1234]
 - 15 **De Veirman K,** Van Valckenborgh E, Lahmar Q, Geeraerts X, De Bruyne E, Menu E, Van Riet I, Vanderkerken K, Van Ginderachter JA. Myeloid-derived suppressor cells as therapeutic target in hematological malignancies. *Front Oncol* 2014; **4**: 349 [PMID: 25538893 DOI: 10.3389/fonc.2014.00349]
 - 16 **Botta C,** Gullà A, Correale P, Tagliaferri P, Tassone P. Myeloid-derived suppressor cells in multiple myeloma: pre-clinical research and translational opportunities. *Front Oncol* 2014; **4**: 348 [PMID: 25538892 DOI: 10.3389/fonc.2014.00348]
 - 17 **Arendt BK,** Walters DK, Wu X, Tschumper RC, Huddleston PM, Henderson KJ, Dispenziera A, Jelinek DF. Increased expression of extracellular matrix metalloproteinase inducer (CD147) in multiple myeloma: role in regulation of myeloma cell proliferation. *Leukemia* 2012; **26**: 2286-2296 [PMID: 22460757 DOI: 10.1038/leu.2012.91]
 - 18 **Taganov KD,** Boldin MP, Baltimore D. MicroRNAs and immunity: tiny players in a big field. *Immunity* 2007; **26**: 133-137 [PMID: 17307699 DOI: 10.1016/j.immuni.2007.02.005]
 - 19 **Fabian MR,** Sonenberg N, Filipowicz W. Regulation of mRNA translation and stability by microRNAs. *Annu Rev Biochem* 2010; **79**: 351-379 [PMID: 20533884 DOI: 10.1146/annurev-biochem-060308-103103]
 - 20 **Perron MP,** Provost P. Protein interactions and complexes in human microRNA biogenesis and function. *Front Biosci* 2008; **13**: 2537-2547 [PMID: 17981733]
 - 21 **Chekulaeva M,** Filipowicz W. Mechanisms of miRNA-mediated post-transcriptional regulation in animal cells. *Curr Opin Cell Biol* 2009; **21**: 452-460 [PMID: 19450959 DOI: 10.1016/j.ccb.2009.04.009]
 - 22 **Bartel DP.** MicroRNAs: genomics, biogenesis, mechanism, and function. *Cell* 2004; **116**: 281-297 [PMID: 14744438]
 - 23 **Kent OA,** Mendell JT. A small piece in the cancer puzzle: microRNAs as tumor suppressors and oncogenes. *Oncogene* 2006; **25**: 6188-6196 [PMID: 17028598 DOI: 10.1038/sj.onc.1209913]
 - 24 **Lotterman CD,** Kent OA, Mendell JT. Functional integration of microRNAs into oncogenic and tumor suppressor pathways. *Cell Cycle* 2008; **7**: 2493-2499 [PMID: 18719378 DOI: 10.4161/cc.7.16.6452]
 - 25 **Meng F,** Henson R, Wehbe-Janek H, Ghoshal K, Jacob ST, Patel T. MicroRNA-21 regulates expression of the PTEN tumor suppressor gene in human hepatocellular cancer. *Gastroenterology* 2007; **133**: 647-658 [PMID: 17681183]
 - 26 **Ekimler S,** Sahin K. Computational Methods for MicroRNA Target Prediction. *Genes (Basel)* 2014; **5**: 671-683 [PMID: 25153283 DOI: 10.3390/genes5030671]
 - 27 **Ebert MS,** Neilson JR, Sharp PA. MicroRNA sponges: competitive inhibitors of small RNAs in mammalian cells. *Nat Methods* 2007; **4**: 721-726 [PMID: 17694064 DOI: 10.1038/nmeth1079]
 - 28 **Kliver J,** Slezak-Prochazka I, Smigielska-Czepiel K, Halsema N, Kroesen BJ, van den Berg A. Generation of miRNA sponge constructs. *Methods* 2012; **58**: 113-117 [PMID: 22836127 DOI: 10.1016/j.ymeth.2012.07.019]
 - 29 **Gutiérrez NC,** Sarasquete ME, Misiewicz-Krzeminska I, Delgado M, De Las Rivas J, Ticona FV, Ferriñán E, Martín-Jiménez P, Chillón C, Risueño A, Hernández JM, García-Sanz R, González M, San Miguel JF. Deregulation of microRNA expression in the different genetic subtypes of multiple myeloma and correlation with gene expression profiling. *Leukemia* 2010; **24**: 629-637 [PMID: 20054351 DOI: 10.1038/leu.2009.274]
 - 30 **Roccaro AM,** Sacco A, Thompson B, Leleu X, Azab AK, Azab F, Rannels J, Jia X, Ngo HT, Melhem MR, Lin CP, Ribatti D, Rollins BJ, Witzig TE, Anderson KC, Ghobrial IM. MicroRNAs 15a and 16 regulate tumor proliferation in multiple myeloma. *Blood* 2009; **113**: 6669-6680 [PMID: 19401561 DOI: 10.1182/blood-2009-01-198408]
 - 31 **Sun CY,** She XM, Qin Y, Chu ZB, Chen L, Ai LS, Zhang L, Hu Y. miR-15a and miR-16 affect the angiogenesis of multiple myeloma by targeting VEGF. *Carcinogenesis* 2013; **34**: 426-435 [PMID: 23104180 DOI: 10.1093/carcin/bgs333]
 - 32 **Zhao JJ,** Lin J, Zhu D, Wang X, Brooks D, Chen M, Chu ZB, Takada K, Ciccarelli B, Admin S, Tao J, Tai YT, Treon S, Pinkus G, Kuo WP, Hideshima T, Bouxsein M, Munshi N, Anderson K, Carrasco R. miR-30-5p functions as a tumor suppressor and novel therapeutic tool by targeting the oncogenic Wnt/ β -catenin/BCL9 pathway. *Cancer Res* 2014; **74**: 1801-1813 [PMID: 24599134 DOI: 10.1158/0008-5472.CAN-13-3311-T]
 - 33 **Zhao JJ,** Carrasco RD. Crosstalk between microRNA30a/b/c/d/e-5p and the canonical Wnt pathway: implications for multiple myeloma therapy. *Cancer Res* 2014; **74**: 5351-5358 [PMID: 25228654 DOI: 10.1158/0008-5472.CAN-14-0994]
 - 34 **Pichiorri F,** Suh SS, Rocci A, De Luca L, Taccioli C, Santhanam R, Zhou W, Benson DM, Hofmainster C, Alder H, Garofalo M, Di Leva G, Volinia S, Lin HJ, Perrotti D, Kuehl M, Aqeilan RI,

- Palumbo A, Croce CM. Downregulation of p53-inducible microRNAs 192, 194, and 215 impairs the p53/MDM2 autoregulatory loop in multiple myeloma development. *Cancer Cell* 2010; **18**: 367-381 [PMID: 20951946 DOI: 10.1016/j.ccr.2010.09.005]
- 35 **Di Martino MT**, Gullà A, Cantafio ME, Lionetti M, Leone E, Amodio N, Guzzi PH, Foresta U, Conforti F, Cannataro M, Neri A, Giordano A, Tagliaferri P, Tassone P. In vitro and in vivo anti-tumor activity of miR-221/222 inhibitors in multiple myeloma. *Oncotarget* 2013; **4**: 242-255 [PMID: 23479461]
- 36 **Pichiorri F**, Suh SS, Ladetto M, Kuehl M, Palumbo T, Drandi D, Taccioli C, Zaneni N, Alder H, Hagan JP, Munker R, Volinia S, Boccadoro M, Garzon R, Palumbo A, Aqeilan RI, Croce CM. MicroRNAs regulate critical genes associated with multiple myeloma pathogenesis. *Proc Natl Acad Sci USA* 2008; **105**: 12885-12890 [PMID: 18728182 DOI: 10.1073/pnas.0806202105]
- 37 **Löffler D**, Brocke-Heidrich K, Pfeifer G, Stocsits C, Hackermüller J, Kretzschmar AK, Burger R, Gramatzki M, Blumert C, Bauer K, Cvijic H, Ullmann AK, Stadler PF, Horn F. Interleukin-6 dependent survival of multiple myeloma cells involves the Stat3-mediated induction of microRNA-21 through a highly conserved enhancer. *Blood* 2007; **110**: 1330-1333 [PMID: 17496199 DOI: 10.1182/blood-2007-03-081133]
- 38 **Xiong Q**, Zhong Q, Zhang J, Yang M, Li C, Zheng P, Bi LJ, Ge F. Identification of novel miR-21 target proteins in multiple myeloma cells by quantitative proteomics. *J Proteome Res* 2012; **11**: 2078-2090 [PMID: 22316494 DOI: 10.1021/pr201079y]
- 39 **Ma J**, Liu S, Wang Y. MicroRNA-21 and multiple myeloma: small molecule and big function. *Med Oncol* 2014; **31**: 94 [PMID: 24981236 DOI: 10.1007/s12032-014-0094-5]
- 40 **Chen L**, Li C, Zhang R, Gao X, Qu X, Zhao M, Qiao C, Xu J, Li J. miR-17-92 cluster microRNAs confers tumorigenicity in multiple myeloma. *Cancer Lett* 2011; **309**: 62-70 [PMID: 21664042 DOI: 10.1016/j.canlet.2011.05.017]
- 41 **Zhang YK**, Wang H, Leng Y, Li ZL, Yang YF, Xiao FJ, Li QF, Chen XQ, Wang LS. Overexpression of microRNA-29b induces apoptosis of multiple myeloma cells through down regulating Mcl-1. *Biochem Biophys Res Commun* 2011; **414**: 233-239 [PMID: 21951844 DOI: 10.1016/j.bbrc.2011.09.063]
- 42 **Amodio N**, Di Martino MT, Foresta U, Leone E, Lionetti M, Leotta M, Gullà AM, Pitari MR, Conforti F, Rossi M, Agosti V, Fulciniti M, Misso G, Morabito F, Ferrarini M, Neri A, Caraglia M, Munshi NC, Anderson KC, Tagliaferri P, Tassone P. miR-29b sensitizes multiple myeloma cells to bortezomib-induced apoptosis through the activation of a feedback loop with the transcription factor Sp1. *Cell Death Dis* 2012; **3**: e436 [PMID: 23190608 DOI: 10.1038/cddis.2012.175]
- 43 **Owen JL**, Iragavarapu-Charyulu V, Gunja-Smith Z, Herbert LM, Grosso JF, Lopez DM. Up-regulation of matrix metalloproteinase-9 in T lymphocytes of mammary tumor bearers: role of vascular endothelial growth factor. *J Immunol* 2003; **171**: 4340-4351 [PMID: 14530359]
- 44 **Asosingh K**, De Raeve H, de Ridder M, Storme GA, Willems A, Van Riet I, Van Camp B, Vanderkerken K. Role of the hypoxic bone marrow microenvironment in 5T2MM murine myeloma tumor progression. *Haematologica* 2005; **90**: 810-817 [PMID: 15951294]
- 45 **Umez T**, Tadokoro H, Azuma K, Yoshizawa S, Ohyashiki K, Ohyashiki JH. Exosomal miR-135b shed from hypoxic multiple myeloma cells enhances angiogenesis by targeting factor-inhibiting HIF-1. *Blood* 2014; **124**: 3748-3757 [PMID: 25320245 DOI: 10.1182/blood-2014-05-576116]
- 46 **Fan GC**. Hypoxic exosomes promote angiogenesis. *Blood* 2014; **124**: 3669-3670 [PMID: 25498451 DOI: 10.1182/blood-2014-10-607846]
- 47 **Raimondi L**, Amodio N, Di Martino MT, Altomare E, Leotta M, Caracciolo D, Gullà A, Neri A, Taverna S, D'Aquila P, Alessandro R, Giordano A, Tagliaferri P, Tassone P. Targeting of multiple myeloma-related angiogenesis by miR-199a-5p mimics: in vitro and in vivo anti-tumor activity. *Oncotarget* 2014; **5**: 3039-3054 [PMID: 24839982]
- 48 **Wu S**, Yu W, Qu X, Wang R, Xu J, Zhang Q, Xu J, Li J, Chen L. Argonaute 2 promotes myeloma angiogenesis via microRNA dysregulation. *J Hematol Oncol* 2014; **7**: 40 [PMID: 24886719 DOI: 10.1186/1756-8722-7-40]
- 49 **Corthals SL**, Sun SM, Kuiper R, de Knecht Y, Broyl A, van der Holt B, Beverloo HB, Peeters JK, el Jarari L, Lokhorst HM, Zweegman S, Jongen-Lavrencic M, Sonneveld P. MicroRNA signatures characterize multiple myeloma patients. *Leukemia* 2011; **25**: 1784-1789 [PMID: 21701488 DOI: 10.1038/leu.2011.147]
- 50 **Brase JC**, Wuttig D, Kuner R, Sultmann H. Serum microRNAs as non-invasive biomarkers for cancer. *Mol Cancer* 2010; **9**: 306 [PMID: 21110877 DOI: 10.1186/1476-4598-9-306]
- 51 **Tagliaferri P**, Rossi M, Di Martino MT, Amodio N, Leone E, Gulla A, Neri A, Tassone P. Promises and challenges of MicroRNA-based treatment of multiple myeloma. *Curr Cancer Drug Targets* 2012; **12**: 838-846 [PMID: 22671926]

P- Reviewer: Georgescu A, Nosaka T **S- Editor:** Wang JL
L- Editor: A **E- Editor:** Wu HL





Published by **Baishideng Publishing Group Inc**

8226 Regency Drive, Pleasanton, CA 94588, USA

Telephone: +1-925-223-8242

Fax: +1-925-223-8243

E-mail: bpgoffice@wjgnet.com

Help Desk: <http://www.wjgnet.com/esps/helpdesk.aspx>

<http://www.wjgnet.com>

